

**S220**

**Cabinet Dimensions (HxLxD):** 90" x 48" x 44"

**Weight:** 1,328 lbs.

\*Actual ship weight may vary

**Capacity:** 2000 CFM@ 3.5 in. W.G.

**Motor:** 2 HP, Direct Drive

**Voltage:** 3 Phase, 480V, 60Hz

**Full Load Amps:** 3.4

**Sound Level:** 72 dBA

**Filter Media Area:** 236 sq. ft.

**Standard Equipment Features**

**Blower:** Reverse inclined high performance blower wheel

**Silencing:** Integral acoustical plenum with low frequency dampening

**Controls:** Manual on/off switch, minihelic filter condition gauge

**Filter Cartridge:** (1) PL-22D14-A15-C

**Filter Type:** Nanofiber MERV15

**Filter Cleaning:** On board compressed air tank, manual activated push-button filter pulse cleaning, 3/4" NPT compressed air connection

**Dust Containment:** Vacuum/sweep out filter plenum

**Spark Arrestance:** Two layers, metal mesh

**Table Size:** 30"D x 48"W

**Heavy Duty Construction:** Fully welded 7 & 11 gauge steel

**Warranty:** Visit [ventboss.com/terms](http://ventboss.com/terms) for full warranty details

**Optional Equipment Features**

**Curtain Kit:** VB-CRT, Weld flash curtain kit includes:curtain, hang bar and brackets

**Light Kit:** VB-LK

**CSA Certification:** CSA-100

**UL Certification:** Contact customer service

**Custom Color**

**Endurex B16 Filter:** PTFE MERV16

**PleatLock M11 Filter:** MERV11

**Other Voltages:** 230V or 575V

**After Filter:** HEPA filter, consult engineering if required, filter adds height to unit behind filter

\*Optional 28" deep side wall extensions available

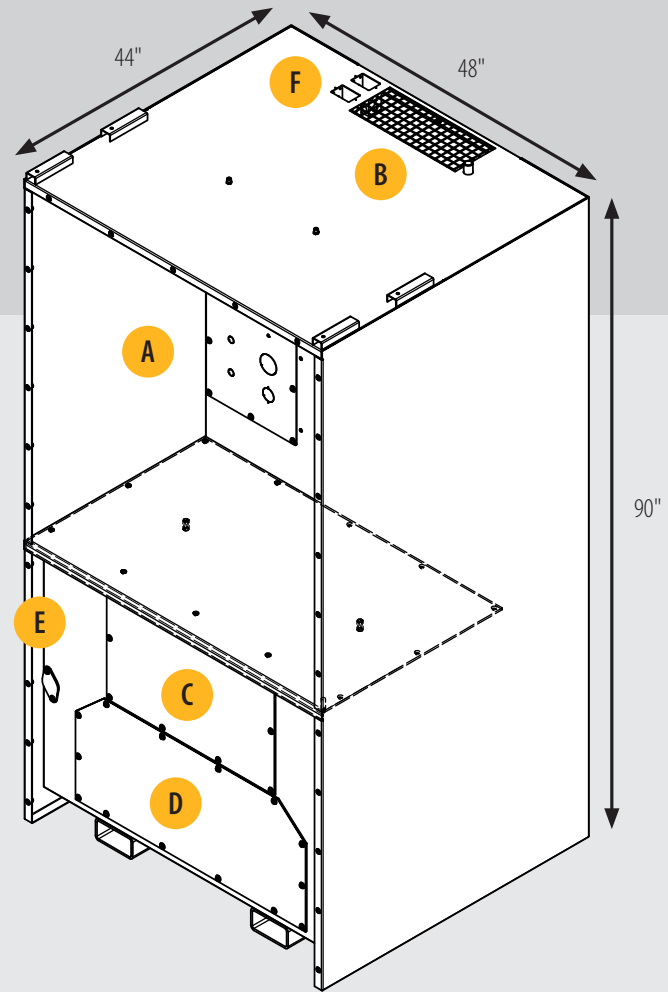

- A** Inlet Area
- B** Clean Air Exhaust
- C** Filter Access
- D** Motor
- E** Particulate Clean-Out
- F** Electrical/Air Hookup

\*Optional 28" deep side wall extensions available

This system is covered by one or more of the following patents: #6,758,875; #4,610,704 and other patents pending. Due to continued engineering, all specifications are subject to change without notice.  
©2023 RoboVent