

HVE-550-80-2

Filter Cartridges: (2) PL-14D36-A15-SF

Media Area: 644 sq. ft.

Weight: 1,350 lbs.*

Regenerative Blower: 15HP Single Stage

Maximum Airflow: 520 CFM

Maximum Vacuum: -80" WG

Voltage & Current: 480V, 3-Phase, 60Hz, 21.7 F.L. Amps

Intake: 5-inch Diameter Air Inlet

Standard Equipment Features

Motor Controls: Motor Starter, Overload & Disconnect all included in controls system, only connection to power supply required, making installation simple and fast

Automatic Filter Cleaning System: Pulse solenoid valve, nozzle, & air tank, with associated pressure differential sensor, enables the responsive filter cleaning in relation to level of accumulated dust, to save air consumption, energy costs & increase filter life

Blower Inlet Flow Relief Valve: Prevents harmful overpressure developing at the blower if flow becomes obstructed, preventing damage to the blower

Heavy Duty Construction: Fully welded 7 & 11 gauge steel, Polyester powder coat inside & out, enhances plant aesthetics & provides excellent equipment durability

HDH Hopper: Hopper & duct Inlet all-in-one with dropout feature to protect filters from larger debris. 20-gallon containment.

Vertical Filter Design: Filters load evenly and easily shed dust right into the containment area, increasing media usage, effectiveness & filter life.

Exhaust Silencing: Blower muffler minimizes generated noise & increases operator comfort (10 to 15 dB(A) sound level reduction approx.)

eDrive™: Built-in VFD adjusts to compensate for filter loading, only connection to power supply required, making installation simple & fast

ePad Controls: A simple, integrated control system at your fingertips

PleatLock A15 Filters

Snaplock Filter Clamps

- Ⓐ Clean Air Exhaust
- Ⓑ Filter Access Door
- Ⓒ Motor (enclosed)
- Ⓓ Compressed Air & Solenoid Access
- Ⓔ Drop-out Hopper with 20-Gallon Drum
- Ⓕ Exhaust Silencer
- Ⓖ Air Inlet (5" Diameter)

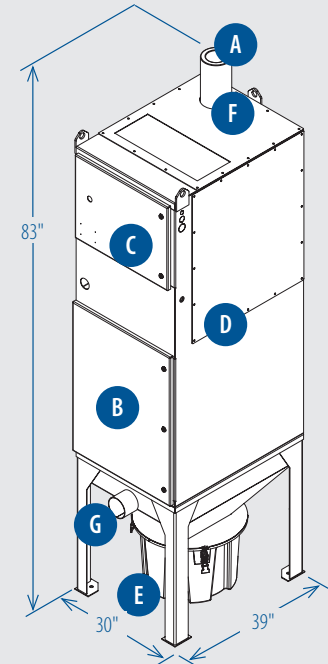

Optional Equipment Features

AutoSaver™: Automatic On/Off feature that reduces energy costs by running the filtration system ONLY when welding/cutting system is operating

Filter Options:

Pleatlock M11: Merv 11 Filters

PleatLock A15: Merv 15 Filters

Endurex B16: Merv 16 ePTFE Filters

Voltage Upgrades: 208, 230 or 575 Volts

Acoustical Attenuation: Stack silencer uses acoustical silencing technology to reduce motor and airflow noise

Delta3™ Spark Arrestor: Superior spark arresstance for welding, grinding & metal cutting applications that enhances safety & protection from fire

FlexTrac: For robotic welding, FlexTrac is attached directly to the robot arm to collect weld fumes right at the source

Safe Sensor: An advanced particulate-monitoring device that detects leaks past the filters, shutting down equipment

Flex Hose

FM 200 Fire Suppression System

Metal Mesh Filter

Sprinkler Heads

HDH Hopper 55-gallon containment

Barrel Level Sensor

Custom Color

eMaster Facility Controls

HEPA Filters

*Weight does NOT include Intakes or any custom options that may be added. For project specific weights, contact the Engineering department.

This system is covered by one or more of the following patents: #6,758,875; #4,610,704 and other patents pending. Due to continued engineering, all specifications are subject to change without notice. ©2018 RoboVent Product Group, Inc. 02/2018