

RDC-2X3-6C

Dimensions w/ intake(s): 97D" x 42W" x 125H"

Base Weight: 4,044 lbs.

Includes base collector, HLL & intake(s)

Equipment

Video Link

Controls: ePro 7" touchscreen for ease of use.

Heavy Duty Construction: Fully welded 7 & 11 gauge steel

Pulsing System: 16 SCFM

Filter Design: Included as standard to improve filter life and reduce energy consumption

Blower/Motor Combination: designed for energy efficiency

SafeSensor Particulate Monitor: detects leaks past the filters

Air Intake: reduces airspeed allowing heavy dust to fall away from filters

Warranty: 15 years on the cabinet; 5 years on components *(See warranty document for details)*

Fire Suppression (optional): FM-200, CO₂, water

Built-in Stack Silencer (optional): for quiet operation

After Filters (optional): HEPA or active carbon

Explosion Vent (optional): part of a complete NFPA package

Specifications

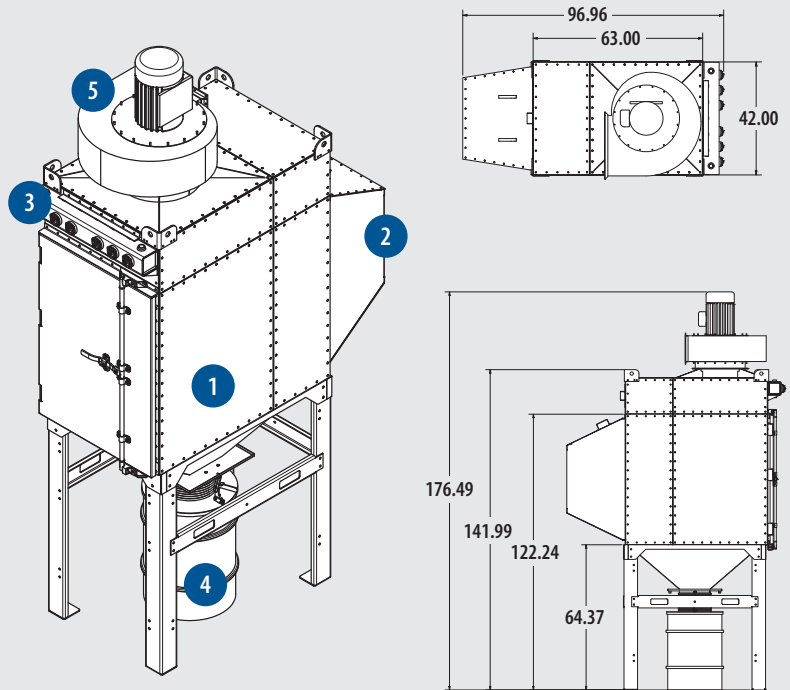

- 1 Filter Cabinet Assembly
- 2 Air Intake
- 3 Advanced Pulsing System

- 4 Dust Containment Bin
- 5 SafeSensor Particulate Monitor

Part No.	Qty.	Configuration	CFM @ "SP*	PL A:C	EX A:C
Motor					
SH-5-1548-PLR-3550-TM	(1)	5 HP • 15 @ 48%	1,500 @ 10.0	0.5:1	1.2:1
SH-10-1708-ALM-3550-TM	(1)	10 HP • 17 @ 100%	2,000 @ 15.0	0.7:1	1.6:1
SH-15-2048-ACF-3550-TM	(1)	15 HP • 20 @ 48%	4,000 @ 15.0	1.4:1	3.2:1
SH-25-2084-ACF-3550-TM	(1)	25 HP • 20 @ 84%	7,000 @ 15.0	2.5:1	N/A
SH-40-2272-ACF-3550-TM	(1)	40 HP • 22 @ 72%	10,000 @ 15.0	3.6:1	N/A
SH-50-2286-ACF-3550-TM	(1)	50 HP • 22 @ 86%	12,000 @ 15.0	4.3:1	N/A

**(Usable static)*

Required Selections	Item Description
Intake Options	
RDC-IT-02	Senturion 2 Wide Standard Intake
RDC-AB-02	Senturion 2 Wide Abrasive Intake**
RDC-SAP-54X54	Senturion 7100-11200 CFM Vortex SAP (side mount only)
RDC-AI-02	Senturion 2 Wide Vortex Ambient Intake
<i>*Must mount on IT Standard Intake</i>	
Containment Options	
RDC-DTP-2X3-6C	Senturion 6-Cartridge Dust Tray (adds 11" to base height)
RDC-HSL-2X3-6C	Senturion 6-Cartridge 20-Gal Hopper & Legs (adds 47" to base height)
RDC-HLL-2X3-6C	Senturion 6-Cartridge 55-Gal Hopper & Legs (adds 65" to base height)
Filter Option	
PL-14D52-M11-SF21-6	Pleatlock M11 Cartridge Filters (MERV 11)
PL-14D52-A15-SF21-6	Pleatlock A15 Cartridge Filters (Nano MERV 15)
EX-14D52-B16-SF21-6	Endurex B16 Cartridge Filters (PTFE MERV 16)
Controls Mounting	
RDC-CTRL-GM	Ground Mounted Control Panel
RDC-CTRL-CM	Collector Mounted Control Panel
RDC-CTRL-WM	Wall Mounted Control Panel
480v & 575v Whip Options (1 Required per Motor)	
15' & 30' Length Available	

Options	Item Description
After Filters	
RDC-HEPA-2X3	Senturion 6-Cartridge Top Mount Pre-Blower HEPA Filter (adds 40" to base collector height)
RDC-CARBON-2X3	Senturion 6-Cartridge Top Mount Post-Blower Carbon Filter
Fire Suppression	
RDC-SPKLR-2X3-6C	Water Sprinkler System
RDC-CO2-2X3-6C-ID	CO ₂ System w/ Intake Damper
RDC-CO2-2X3-6C	CO ₂ System w/out Intake Damper
RDC-FM200-2X3-6C-ID	FM200 Fire Suppression System w/ Intake Damper
RDC-FM200-2X3-6C	FM200 Fire Suppression System w/out Intake Damper
Service Platform	
Senturion 2-Wide Service Platform (Includes rails, gate(s) and ladder)*	
<i>*Adds 65" to door side of collector</i>	
NFPA Options	
ST1 NFPA Standard Package*	
ST2 NFPA Standard Package*	
<i>*Requires selection of HLL option. Includes RAL, explosion vents & controls</i>	
Options and Upgrades	
CMR-20	AutoSaver Sensor
SSG-DTS	SuperSeal Hopper Gate
BLS-110	Barrel Sensor (requires RDC-CTRL-EX)
RDC-CTRL-EX	Controls Expansion Module (required for BLS or summer/winter dampers)
Vortex Options	
RDC-VORTEX-2X3	Senturion 6-Cartridge Vortex Plenum*
<i>*Includes: 40HP 2275 Motor/Blower, adds 42.73" to base height</i>	

Additional Resources and Downloads (click image to retrieve material)



Owner's Manual

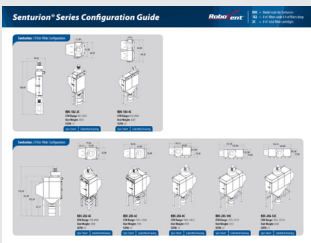

Equipment Configurations



Product Video

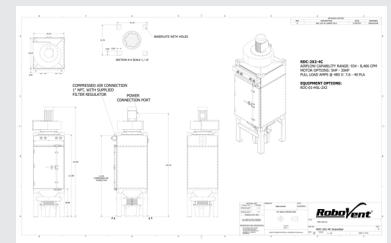

Submittal Drawing