

MODEL

G120



Maximum filter life will be achieved with this product when one welder is welding up to 50 pounds of weld wire per week.



Capacity: 1200 CFM @ 4.5 in.W.G.

Motor: 1.5 HP, Direct Drive

Voltage: Single phase, 110V, 60Hz

Full Load Amps: 20.0

Blower: Reverse inclined high performance blower wheel

Sound Level: 70 dBA

Silencing: Integral Acoustical Plenum with Low Frequency Dampening

Controls: Manual on/off switch, Minihelic Filter Condition Gauge

Cabinet Dimensions (HxLxD): 53" x 23" x 31"

Weight: 440 lbs.

Filter Cartridge: (1) PL-14D26-A15-SF

Filter Media Area: 231 sq.ft.

Filter Type: Nanofiber MERV15

Filter Cleaning: On board compressed air tank, manual activated push-button filter pulse cleaning, 1/4"NPT compressed air connection

Dust Containment: Lift-out Dust Tray

Spark Arrestance: (1) Metal Mesh Screen MM-20242

Configurations:

- **G120:** (1) 8" Diameter, 10' long fume arm

Options:

- 8" FumeArm LED Light Kit — VB-HD-8LK (included)
- CSA Certification — CSA-100
- UL Certification — Contact Customer Service
- HEPA Filter & Frame : HP-S120 (required for attachment)
- HEPA Replacement Filter: HP-S120-HF (Note: HEPA filter reduces airflow by approximately 10%)

Warranty:

Visit ventboss.com/terms for full warranty details.

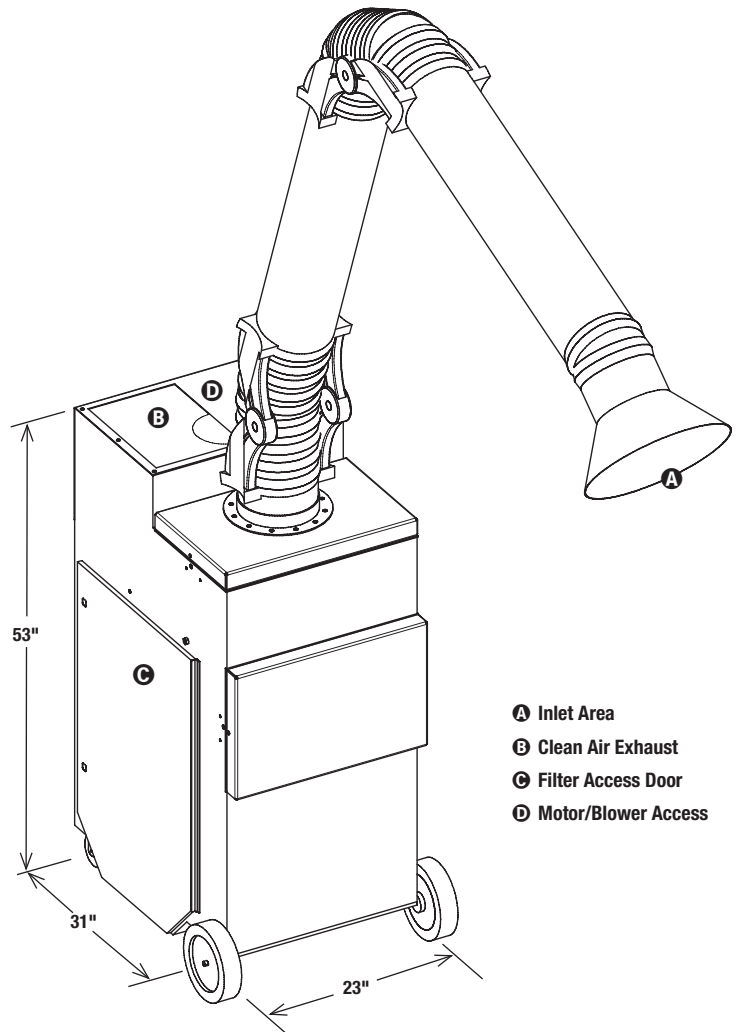

- Ⓐ Inlet Area
- Ⓑ Clean Air Exhaust
- Ⓒ Filter Access Door
- Ⓓ Motor/Blower Access