

MODEL

S210



Maximum filter life will be achieved with this product when one welder is welding up to 25 pounds of weld wire per week or grinding small weldments



Capacity: 1280 CFM @ 4 in.W.G.

Motor: 0.75 HP, Direct Drive

Voltage: Single phase, 110V, 60Hz

Full Load Amps: 13.8

Blower: Reverse inclined high performance blower wheel

Sound Level: 67 dBA

Silencing: Integral Acoustical Plenum with Low Frequency Dampening

Controls: Manual on/off switch, Minihelec Filter Condition Gauge

Cabinet Dimensions (HxLxD): 52" x 37" x 29"

Weight: 420 lbs.

Filter Cartridge: (1) PL-22D12-A15-C

Filter Media Area: 201 sq. ft.

Filter Type: Nanofiber MERV15

Filter Cleaning: On board compressed air tank, manual activated push-button filter pulse cleaning, 3/4"NPT compressed air connection

Dust Containment: Vacuum / sweep out filter plenum

Spark Arrestance:

Triple Layer, (1) FB-24242, (2) MM-24242

Configuration: Table Size: 36 x 36in, 1 x 1/8 Bar Grating, 300lb. Load capacity

Options:

- Caster Wheel Kit — WK-S200
- CSA Certification — CSA-100
- UL Certification — Contact Customer Service
- HEPA Replacement Filter: HP-S211-HF (Note: HEPA filter reduces airflow by approximately 10%)

Warranty:

Visit ventboss.com/terms for full warranty details.

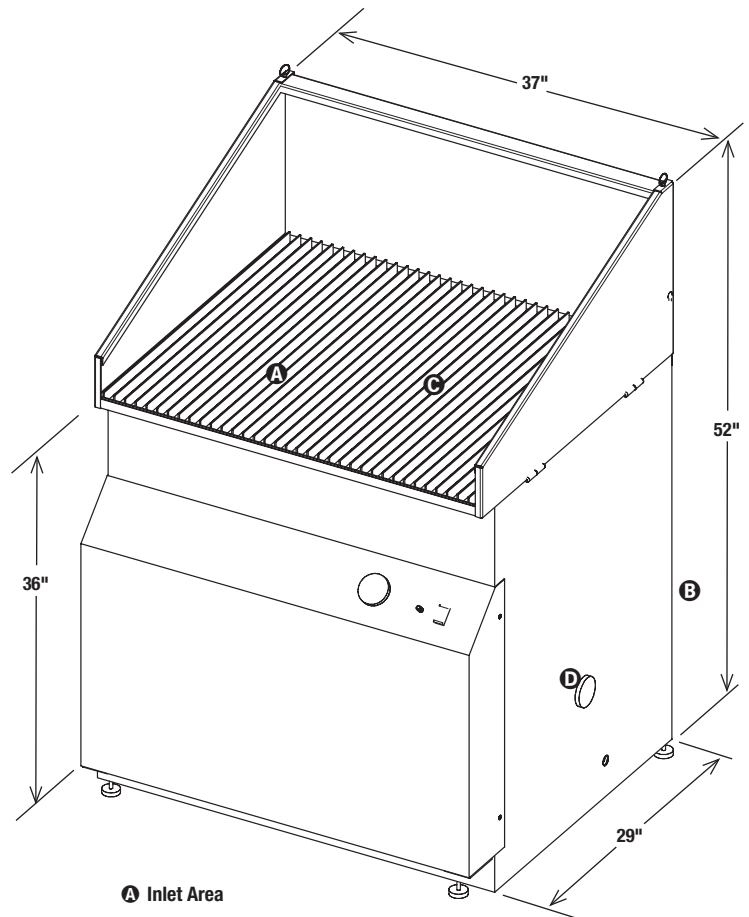

- Ⓐ Inlet Area
- Ⓑ Clean Air Exhaust (on back)
- Ⓒ Filter & Spark Arrestance Access
- Ⓓ Particulate Clean-Out