

MODEL

S211



Maximum filter life will be achieved with this product when one or two welders are welding up to 50 pounds of weld wire per week.



Capacity: 2560 CFM @ 4 in.W.G.

Motor: 1.5 HP, Direct Drive

Voltage: Single Phase, 110V 60Hz

Full Load Amps: 20.0 (110V)

Blower: Reverse inclined high performance blower wheel

Sound Level: 72 dBA

Silencing: Integral Acoustical Plenum with Low Frequency Dampening

Controls: Manual on/off switch, Minihelic Filter Condition Gauge

Cabinet Dimensions (HxLxD): 52" x 61" x 29"

Weight: 700 lbs.

Filter Cartridge: (2) PL-18D12-A15-C

Filter Media Area: 284 sq. ft. total

Filter Type: Nanofiber MERV15

Filter Cleaning: On board compressed air tank, manual activated push-button filter pulse cleaning, 3/4" NPT compressed air connection

Dust Containment: Vacuum / sweep out filter plenum

Spark Arrestance:
Triple Layer, (2) FB-24242, (4) MM-24242

Configuration: Table Size: 60 x 36in, 1 x 1/8 Bar Grating, 630lb. Load capacity

Options:

- Caster Wheel Kit — WK-S200
- CSA Certification — CSA-100
- UL Certification — Contact Customer Service

Warranty:

Visit ventboss.com/terms for full warranty details.

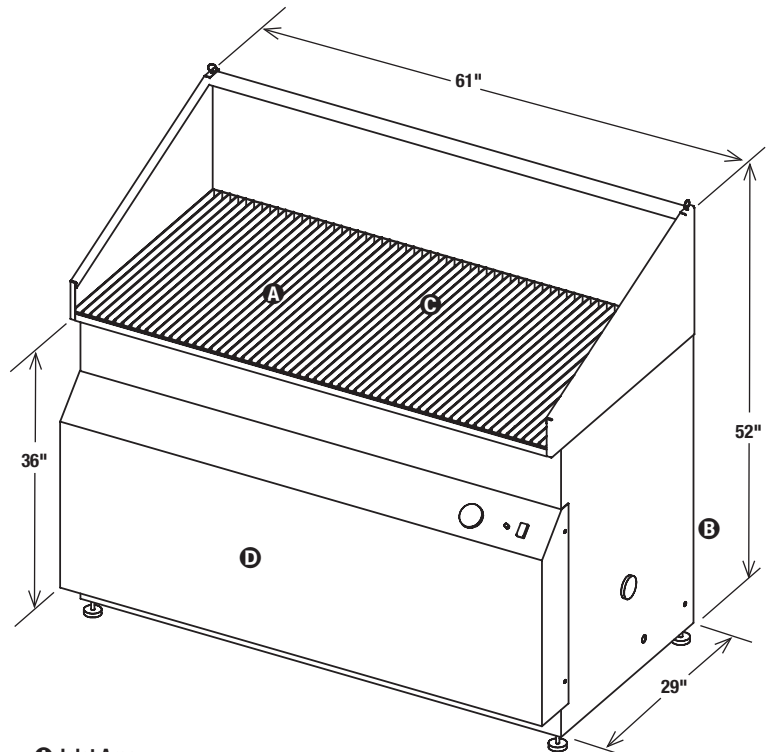

- A** Inlet Area
- B** Clean Air Exhaust (on back)
- C** Filter & Spark Arrestance Access
- D** Particulate Clean-Out