

VENT BOSS[®]
by **RoboVent**[®]

SERIES 200

PLUG-N-PLAY WORKSTATIONS



MODEL
S220

**OWNER'S
MANUAL**

Installation,
Operation
& Maintenance



OWNER'S MANUAL

Installation, Operation & Maintenance

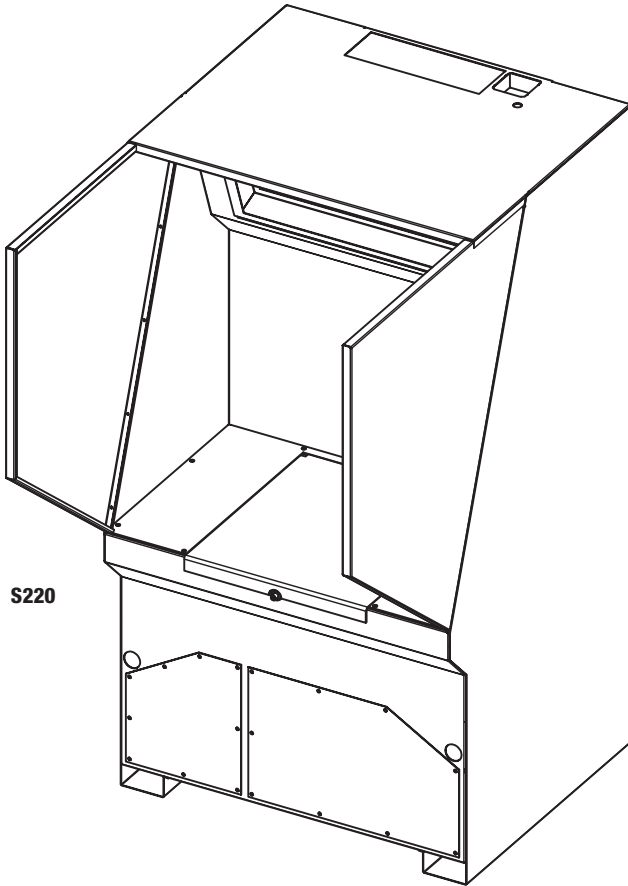

S220

Manufactured by:

RoboVent

37900 Mound Road Sterling Heights, MI 48310 USA

(855) 558.VENT www.ventboss.com

©2017 RoboVent All rights reserved.

CONGRATULATIONS!

Dear Customer,

Thank you for purchasing a VentBoss product. This manual will help you use the many features available to customize the unit to your specific welding needs.

At VentBoss we are committed to making your facility a safe and healthy environment for your workers. Please take time to read this manual thoroughly before installing and operating the unit.

When your VentBoss needs scheduled maintenance, keep in mind that VentBoss has specially trained staff in servicing our equipment. If you would like to schedule service, or if you have a question or concern regarding your VentBoss product, please contact us at:

(855) 558.VENT or **customer.service@ventboss.com**.



TABLE OF CONTENTS

Important Safety Instructions	Section 100	Page 6
Features of the S220	Section 200	Page 7
Receiving & Inspection	Section 300	Page 9
Installation	Section 400	Page 10
Operation	Section 500	Page 11
General Maintenance Procedure	Section 600	Page 12
Troubleshooting	Section 700	Page 15
Wiring Diagram	Section 800	Page 16

IMPORTANT SAFETY INSTRUCTIONS



Failure to follow all instructions may result in electric shock, bodily injury and/or destruction of the unit



Use of controls, adjustments, or performance of procedures other than those specified herein, may result in electrical shock.

IMPORTANT SAFETY INSTRUCTIONS

1. Read all instructions thoroughly.
2. Heed all warnings.
3. Do not block intake or exhaust vents. Keep the exhaust vent free from debris and materials that could restrict airflow. Prolonged restriction could damage the motor and electrical components. Any blockage of the air flow will decrease efficiency of this unit.
4. Refer all service matters to qualified service personnel. Servicing is required when the unit is damaged in any way including the control panel, supply wiring or in the case of excessive filter loading.
5. **Risk of serious injury or death!** Use extreme care to make sure you are never in a position where your body (or any item you are in contact with, such as a screwdriver or test instrument) can accidentally touch the blower wheel.
6. **Disconnect power before working on the motor or blower wheel. The motor or blower wheel should be disassembled only by a factory authorized technician.**



SECTION 200

FEATURES OF THE S220



FIGURE 1

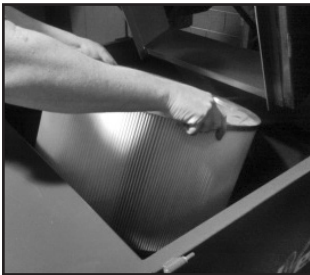
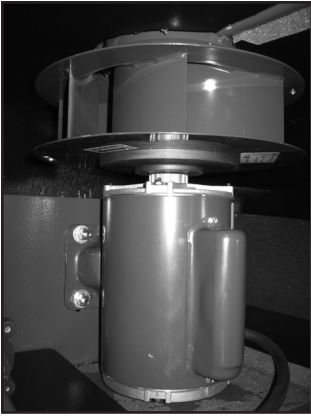
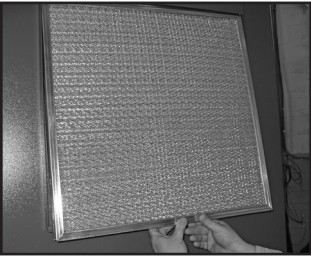

FIGURE 2

- 1. Filtration System:** The VentBoss S220 Workstation is a fume collector for use in intermittent duty or light production applications. The heavy duty construction and versatility of the S220 Workstation puts it at the front of its class of air cleaners 2000 CFM or less
- 2. Vertical Filter Design (Standard):** Vertically aligned filters allow the dust to shed off the filter and fall directly down into the containment system. The unique vertical design increases filter life by 30% to 40% over traditional horizontal filter placement.
- 3. Manual Filter Cleaning:** The VentBoss S220 Workstation comes equipped with an Filter pulse Cleaning design that allows the oversized vertical cartridge filter to be back flushed with compressed air. See “Cleaning the Cartridge Filter”. Figure 1.
- 4. Easy Filter Access:** For your convenience, the VentBoss S220 Workstation has an easy access filter element. No special tools are required to access the filter plenum, just release two latches, lift up the table top and remove the filter. Filters can be changed in only a few minutes with no more effort than swinging up the table top. Figure 2.
- 5. Heavy Duty Construction:** Each WeldVent fume collector comes with our heavy duty 14 gauge steel construction and quality built guarantee. A durable baked on powdercoat finish assures a lifetime of use.
- 6. High Grade A13 Filter:** A High Grade A13 Filter comes standard with each VentBoss S220 workstation which contributes to its high efficient filtration and is leak tested and precoated for maximum particulate release. This durable filter can be back-pulsed countless times, and still give endless hours of filtration.

**FIGURE 3****FIGURE 4**

- 7. High Performance Blower:** The aluminum Acoustafoil blower is the heart of the WeldVent units. This High Performance Blower is engineered for High Output air volume with 6.7" of maximum static pressure. Figure 3.
- 8. Quiet Operation:** A built-in acoustic lining of high density sound absorbing materials has been implemented as part of the blower compartment. The acoustically designed plenum greatly reduces motor and blower noise levels and decreases ambient noise to the facility.
- 9. Built-In Spark Arrestance:** The WeldVent internal SparkOut plenum quickly extinguished sparks created through the welding or grinding process. Figure 4.

Receiving

VentBoss equipment is typically shipped on skids or in crates. The number of skids/ crates will vary, depending on the type, size and accessories ordered. These skids/ crates are too heavy to lift by hand, and will need to be unloaded by an industrial forklift or similar equipment.

Inspection

A visual inspection of your equipment should be performed before it is removed from the truck. Dents, scratches, and other damages should be noted on the shipping documents, and also photographed. The structural integrity of the housing can be adversely affected by large dents. VentBoss should be immediately notified of any structural damage to your equipment. It is the purchaser's responsibility to file shortage reports and damage claims with the carrier and with your VentBoss Representative. The carrier is responsible for any damage to the equipment while it is in transit unless specific arrangements are made otherwise.

Compare the number of items received against the carrier's bill of lading. Inspect all items for apparent damage. Immediately report any shortages or obvious damage to the carrier and to your local VentBoss Representative, call the factory at 1 (855) 558.VENT, or email: customer.service@ventboss.com.

When all skids are completely unpacked and uncrated, check all items received against the packing lists. Further inspect the unit and components for hidden damage. Again, report any shortage or damage to the carrier and to your local VentBoss Representative.

The filter cartridges are typically shipped installed in your collector. Be sure to check them for alignment, as they may have shifted during transit. If they have shifted, it is possible that damage may have been done. Remove all filter cartridges and inspect thoroughly.

Note: Do not return any damaged components without first contacting your VentBoss Representative to obtain a Returned Goods Authorization (RGA).

Small Parts

Carefully inspect all packing material before it is discarded, to be sure that no small parts have been missed.

SECTION 400

INSTALLATION

The VentBoss S220 Workstation comes pre-assembled for immediate use. Please go through the packing list to make sure you have all the required parts. The cartridge filter and spark arrestance filters and baffles are already installed inside the unit.

Electrical Hook-Up

The VentBoss S220 Workstation comes as a 480 volt 3-phase model. The connection must be done by a licensed electrician and in accordance with NEC and all applicable local codes.

SECTION 500 OPERATION



FIGURE 5



FIGURE 6

Pulsing the Series 200 Workstation (Cleaning the Cartridge Filter)

The VentBoss S220 Workstation comes equipped with a Manual Pulsing System (MPS) located on the front or right side of the collector. Figure 5. To operate, compressed air must be hooked up to the air inlet. (See Compressed Air Hook-Up)

After each days use, press the solenoid plunger 5-15 times to back-flush the filter cartridge. This cleaning process will loosen the collected particulate from the cleaning cartridge and will be collected in the tray below.

For best results, press the solenoid plunger in short, timed blast of 3-5 seconds between each pulse. The motor **MUST** be turned off for this process.

Compressed Air Hook-Up

IMPORTANT! First and foremost, your VentBoss Series 200 Workstation needs a clean, dry compressed air source, approximately 80 to 90 PSI.

Many problems can be traced back to the presence of oil or water in the compressed air system. If contamination is present, both the cartridges and cleaning system will suffer.

An appropriately sized quick fit air-line connector will need to be threaded into the provided 3/4" NPT adapter (Figure 6). A permanent line can be directly connected to the accumulator tank or a shop air hose can be used when back flushing the filters.

Note: These procedures are to be performed while there is no welding occurring!

Replacing the Filter Cartridge

The high grade Endurex A13 filter of the VentBoss S220 can be back-pulsed multiple times and before it needs replaced. Prior to making a decision to replace the filter, first follow the procedures of “Pulsing the Series 200 Workstation”. The cartridge can also be taken out and manually cleaned with compressed air. If the Downdraft collector still does not draw sufficiently, then replace the cartridge.

To replace the filter cartridge, unlatch the two draw latches on the right and left sides of the unit. Lift the table top until it is fully open. Note that the top is secured by two lanyards. This will keep the top from falling back behind the table.

Pull the large diameter filter straight up and out the top of the unit and discard in an appropriate container.

Replace the filter with a new VentBoss replacement cartridge. Insert the new cartridge making sure it is securely seated on the filter ring just above the blower opening. Once the cartridge is seated in place you can close the top plate over the filter and latch the draw latches until they pull the bar-grate top down onto the cartridge filter. This seals the filter and keeps particulate from entering the clean air plenum.

Replacement filters may be ordered by calling VentBoss at 1-855-558-VENT.

Replacing the Metal Baffle Filters

The VentBoss S220 Workstation comes equipped with three internal baffle filters located in the spark arrestance plenum. This plenum is located right under the top bar-grate.

To access this plenum first follow procedures under “Replacing the Filter Cartridge.” Lift the table top and remove the (4) 5/16" bolts located on the bottom side of the top plate as shown. (The bar-grate will be loose so make sure it is fully supported during this process.) Remove the bar-grate.

The first spark arrestor will be the metal Baffle Filter. Remove this filter and clean. The next two filters will be the metal mesh filters. These two filters should always be placed below the first Baffle Filter.

All the spark arrestance baffles should be removed and cleaned on a regular basis (check every two weeks). If particulate builds up on these baffles the risk of fire in the system is greatly increased. Typically, these baffles should be removed and cleaned



FIGURE 7



FIGURE 8

with a hot detergent solution every month. Filters that are bent or deformed beyond repair should be replaced. See “Specifications” for ordering proper replacements.

CAUTION! DO NOT replace these baffle filters with anything other than what was originally installed in your unit. Failure to do so will greatly increase the risk of fire.

Placement of the first layer baffle filter is extremely important as the baffles should run vertical with cup side facing toward the top of the collector. Failure to place the baffle in this way will increase the risk of fire.

Particulate Removal (Cleaning)

After several hours of operation the VentBoss Series 200 Workstation will need to be cleaned. Before cleaning back flush the filter by following the procedure in Section 600 of Pulsing the Series 200 Workstation. Give each filter several cleaning pulses. Make sure the Air Hook-Up is connected to a 80-90 psi dry air.

The VentBoss S220 has two dust bin areas located on either side of the unit. This area is accessed from outside the unit by a rubber plug. Turn the wing nut counterclockwise until the plug becomes loose (Figure 7). Remove and insert the suction end of a shop vacuum into the cleanout port until you get a good seal (Figure 8). Turn on the vacuum until all the dust is removed. Repeat for the other side of the unit.

Cleaning frequency of the dust bins will vary depending on the welding situation and use. Periodically check the tray for particulate. When 2-3 inches of dust forms at the bottom of the bin remove with a vacuum.

Blower Maintenance

The motor and blower in your VentBoss Series 200 Workstation will require very little attention, although it is important to make sure it is kept clean. If your motor is fitted with grease nipples, they must be lubricated every six months.

Installation of a new blower wheel requires a certified VentBoss Technician to balance the wheel and motor. Contact 1-855-558-VENT.

Access to the motor, blower, air accumulator tank and solenoid is through the back panel. Do not open this panel without performing a full OSHA Lockout Procedure. Remove the panel as shown.

Solenoid Valve Maintenance

The Pulse Solenoid is located on the side of the accumulator tank as shown below. Under normal conditions, the pulse valve will last for the life of the collector. Clean, dry compressed air, at 90 PSI, will assure long, maintenance free life of the solenoid.

(See Specifications for replacement)

SECTION 700

TROUBLESHOOTING

The VentBoss Series 200 Workstation is making excessive noise. Check the following:

1. Make sure the blower wheel is not hitting against the bottom filter plate.
2. Check that all motor bolts are securely tightened.
3. Make sure motor bearings are good. (Amperage rating will be higher than normal.)
4. Blower wheel could be out of balance. If the blower wheel has gone out of balance, there will be excessive vibration. In this case, please contact the VentBoss Technical Department at 1.855.558.VENT.

Manual Pulse Filter Cleaning System is not operating:

1. Verify that the airline is connected to the air tank.
2. Check air tank pressure. The pulse valve works best when pressurized at 85 PSI maximum.
3. Check diaphragm on solenoid valve. If the correct pressure is supplied to the air tank then a problem may exist with the solenoid diaphragm. See Specifications Sheet to order a new diaphragm kit or complete valve from VentBoss Service Department.

Little or no suction across intake. Check the following:

1. Cartridge filter is loaded. Review “Pulsing the VentBoss Series 200 Collector” in Section 600 under OPERATION. With the air hooked up press the Solenoid Plunger 25-30 times with a 3-5 second spacing between each pulse. Make sure the unit is turned off for this process.
2. If using a fume arm make sure the butterfly valve behind the intake hood is not closed. Sometimes this valve will close on it's own, cutting off most of the air supply.

Cartridge filter loads up but no dust in the dust tray. Check the following:

1. Check that the Manual Pulsing System is working properly.
2. Check for oil or moisture on the filter media. If oil or moisture exists in the air supply it will transfer to the cartridge.
3. In some cases high oil content is introduced in the welding process causing the oil to vaporize. This will cause the cartridge filters to load up prematurely. Call the VentBoss Service Department at 1.855.558.VENT for more information.

SECTION 800 WIRING DIAGRAM

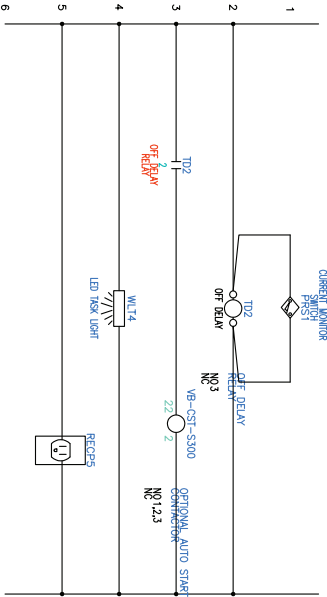
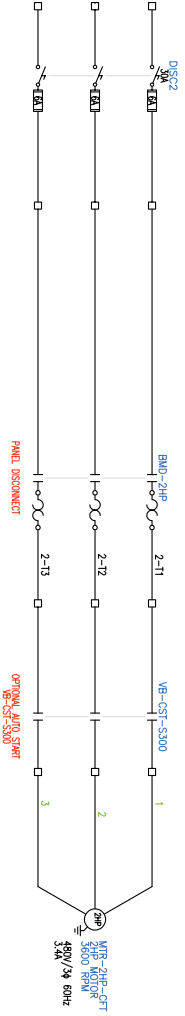

Time Delay Relay

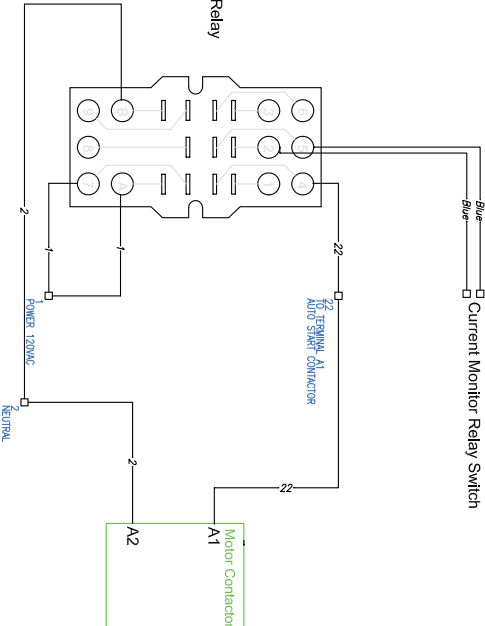

VENTBOSS[®]
by **RoboVent**[®]

37900 Mound Road Sterling Heights, Michigan 48310 USA
855.558.VENT • WWW.VENTBOSS.COM