

MODEL

S315



Maximum filter life will be achieved with this product when one or two welders are welding up to 75 pounds of weld wire per week.



Capacity: 1500 CFM @ 4.5 in.W.G.

Motor: 2HP, Direct Drive

Voltage: 3 Phase, 480V, 60Hz

Full Load Amps: 3.4

Blower: Reverse inclined high performance blower wheel

Sound Level: 72 dBA

Silencing: Integral Acoustical Plenum with Low Frequency Dampening

Controls: Manual on/off switch, Minihelic Filter Condition Gauge

Cabinet Dimensions (HxLxD): 67" x 24" x 24"

Weight: 370 lbs.

Filter Cartridge: (1) PL-14D36-A15-SF

Filter Media Area: 320 sq. ft.

Filter Type: Nanofiber MERV15

Filter Cleaning: On board compressed air tank, manual activated push-button filter pulse cleaning, 1/2"NPT compressed air connection

Dust Containment: Vacuum / sweep out filter plenum

Spark Arrestance:
(1) FB-24242, (1) MM-24242

Configuration:
FloorSaver with Intake Boot and Spark Arrestance

Options:

- Wall Bracket Kit — S300-WK-FA (**INCLUDED**)
- CSA Certification — CSA-100
- UL Certification — Contact Customer Service
- HEPA Filter — HP-S310
HEPA Frame — HFR-S310
- Other Voltages: 230V or 575V

Warranty:

Visit ventboss.com/terms for full warranty details.

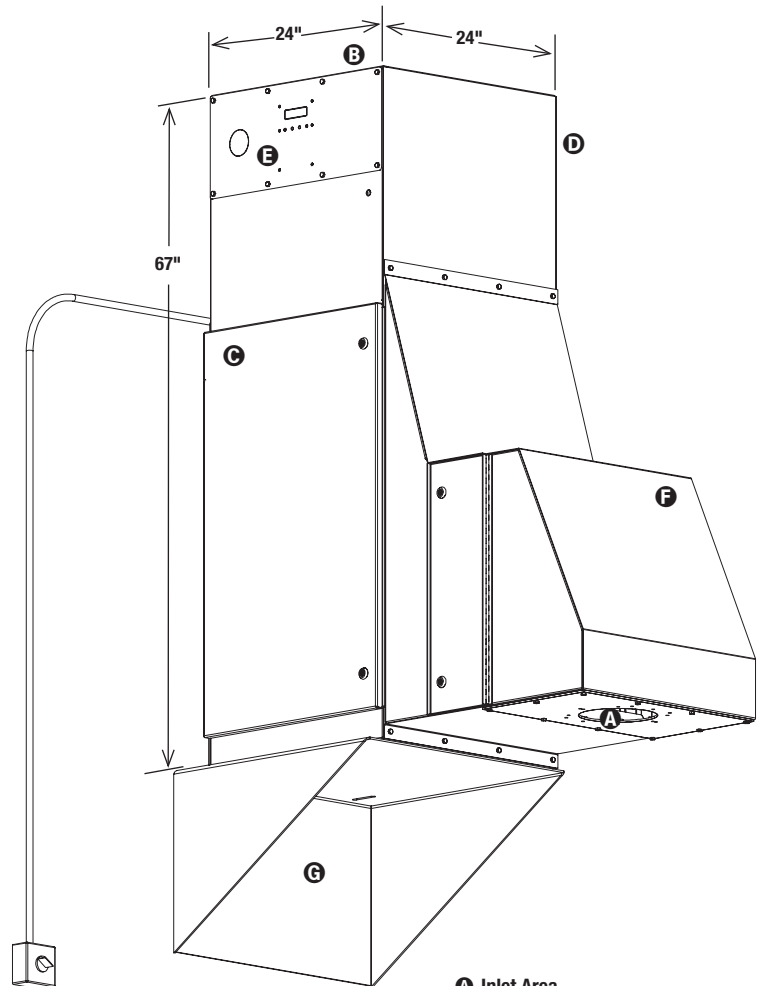

- A** Inlet Area
- B** Clean Air Exhaust
- C** Filter Access Door
- D** Motor/Blower Access (on side)
- E** Minihelic Filter Gauge or Optional Digital Controller
- F** Intake Transition and Spark Arrestance
- G** Wall Bracket Kit (optional)