

RDC-1X2-2C

Dimensions w/ intake(s): 36D" x 42W" x 167H"
Height based on HLL

Base Weight: 2,433 lbs.
Includes base collector & HLL containment

Airflow Capability: 4,000 CFM

Motor Option: 10 HP

Full Load Amps @ 480 V: 14 FLA

Static Pressure: 10 in. wg

Filter Cartridges: (2) PL-14D52-A15-SF21

Comparable Filter Media: 930 sq. ft.

Equipment

Video Link

Controls: ePro 7" touchscreen for ease of use.

Heavy Duty Construction: Fully welded 7 & 11 gauge steel

Pulsing System: 16 SCFM

Filter Design: Included as standard to improve filter life and reduce energy consumption

Blower/Motor Combination: Designed for energy efficiency

SafeSensor Particulate Monitor: Detects leaks past the filters

Air Intake: Reduces airspeed allowing heavy dust to fall away from filters.

- SAP: Metal mesh/baffle intake - Standard
- Ducted Intake: Optional

Warranty: 15 years on the cabinet; 5 years on components (*See warranty document for details*)

Fire Suppression (optional): Water - contact engineering if chemical systems are needed

Vortex Plenum: With adjustable nozzles

After Filters (optional): HEPA or active carbon*, both options reduce air flow

Containment: Various containment options including a dust tray, HSL, HLL

**After filters option reduces airflow down to 2,802 CFM*

Specifications

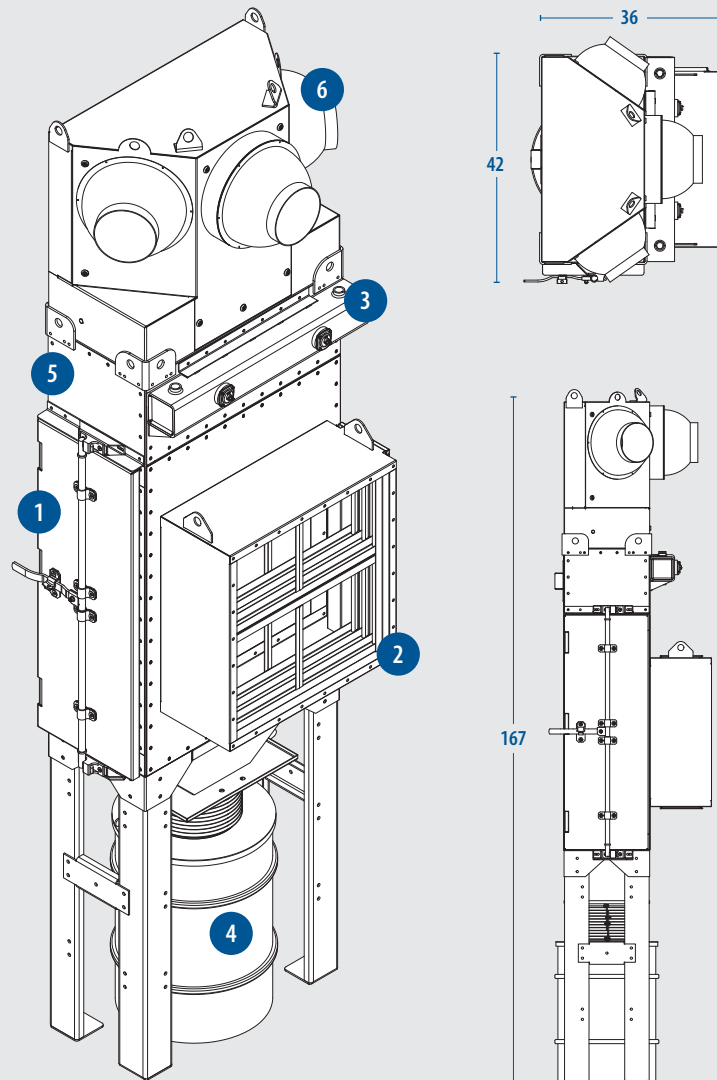

- | | |
|--|---|
| <ul style="list-style-type: none"> 1 Filter Cabinet Assembly 2 Air Intake 3 Advanced Pulsing System 4 Dust Containment Options (HLL Shown) | <ul style="list-style-type: none"> 5 SafeSensor Particulate Monitor 6 Vortex Top Plenum: Exhaust Plenum with Adjustable Louvers |
|--|---|